

**Towbar: AK4558**  
**For: Motorhomes With Al-Ko Chassis (From 2006)**  
**Revision: 1**

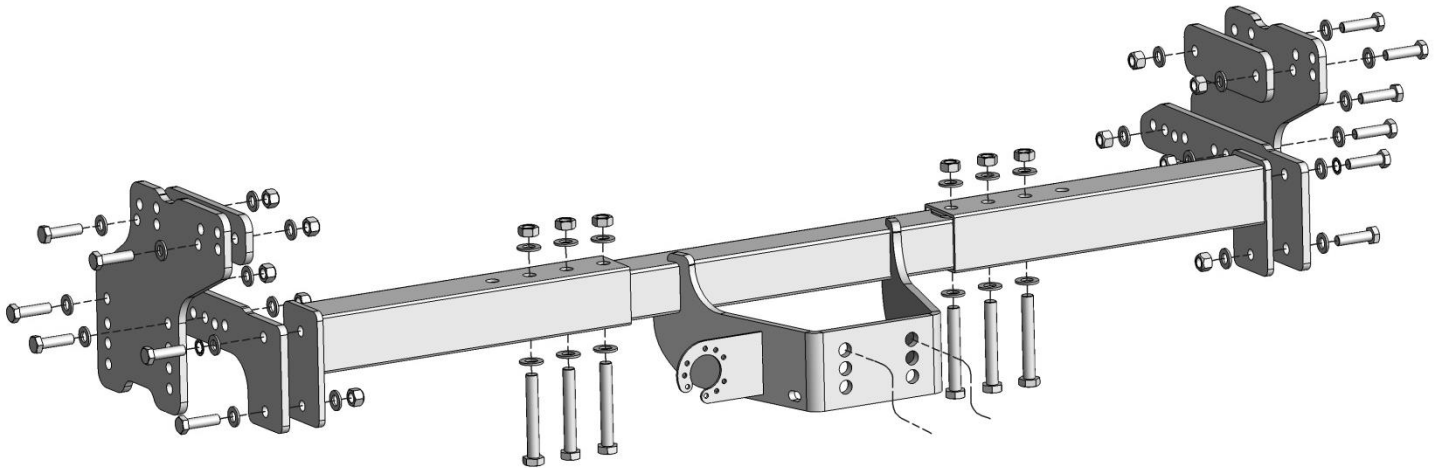

# **TOWBAR: AK4558**

# **INSTALLATION INSTRUCTION**

**Towbar: AK4558**  
**For: Motorhomes With Al-Ko Chassis (From 2006)**  
**Revision: 1**



## **PARTS LIST**

<b>Item</b>	<b>Quantity</b>	<b>Description</b>
A	1	Towbar Cross Member
B	2	Towbar Cross Member Extension
C	2	Spacer Plate (Used on Certain Applications)
D	2	Side Arms
E	2	Side Plates
F	2	Spreader Plate
CP	1	10mm Coupling Packer
TB	1	Towball Coupling – 50mm
TC	1	Towball Boot Cover

## **BOLT PACK**

<b>Item</b>	<b>Quantity</b>	<b>Description</b>
G	2	M16 x 55 Coupling Bolts & M16 Nyloc Nuts
H	6	M14 x 90 Bolts & M14 Nyloc Nuts
J	12	M12 x 50 Bolts & 10x M12 Nyloc Nuts
K	12	M14 Washer – 28mm O/D x 2mm Thick
L	22	M12 Washer – 23mm O/D x 1.6mm Thick
M	2	M12 Shakeproof Washers
CAP-M14	12	M14 Bolt Cover
CAP-M12	10	M12 Bolt Cover

## **INSTALLATION NOTES**

- Always read the instructions thoroughly before commencing installation.
- Check that the towbar is suitable for your make & model.
- Due to variances in vehicle specification compatibility cannot be guaranteed.
- Leave all components loose until assembled unless instructed in the installation instructions. This will ensure any vehicle to vehicle variances are overcome.
- Recommended Torque Settings:
  - M12 x 1.75 Pitch: 102Nm, M14 x 2.0 Pitch: 141Nm, M16 x 2.0 Pitch: 252Nm
- The towing limits & static nose load limit stated by the vehicle manufacturer must never be exceeded.
- Maintenance should be carried out periodically. This should include, but not be limited to, bolt tightness, corrosion to the towbar and/or mounting areas, coated finish etc.
- Full Terms & Conditions are available upon request.

## INSTALLATION PROCEDURE

- Locate the correct installation diagram representative of your vehicle make & model on one of the following pages.
- All Models: Insert towbar cross member extensions (B) into each end of towbar cross member (A) ensuring the correct orientation of the end plates for your vehicle make and model. Slide each cross member extension to the desired position representative of the vehicle's chassis width and loosely attach using bolts & nyloc nuts (H), with M14 flat washers (K) under both bolt heads and nuts. Ensure the bolt heads are 'underneath' the towbar.
- Only Model Illustrations: Swift-2, Swift-5, Swift-8, Swift-9, Bailey-1, Bailey-3.
  - Locate the two towbar mounting holes at the end of each chassis rail or chassis extension. Using the correct hole configuration, loosely attach side arms (D) to the outside of the chassis with bolts (J) and washers (L). If desired, spreader plates (F) can be used on the opposite side of the chassis rail/chassis extension.
  - Insert towbar cross member assembly (A) & (B) between side arms (D) and loosely attach using bolts (J) washers (L) & washers (M). On certain models, it is necessary to use spacer plate (C) between the cross member assembly and side arms (D).
- Only Model Illustrations: Swift-1, Swift-3\*, Swift-4, Swift-6, Swift-7, Swift-10, Bailey-2\*.
  - Locate the two towbar mounting holes at the end of each chassis rail or chassis extension. Using the correct hole configuration, loosely attach side plates (E) to the outside of the chassis with bolts (J) and washers (L). If desired, spreader plates (F) can be used on the opposite side of the chassis rail/chassis extension. \* On Swift-3 & Bailey-2 models, it is necessary to use spreader plates (F) between side plates (E) and the vehicle chassis/chassis extensions as a spacer.
  - Loosely attach side arms (D) to side plates (E) using bolts (J) and washers (L) ensuring the correct orientation.
  - Insert towbar cross member assembly (A) & (B) between side arms (D) and loosely attach using bolts (J) washers (L) & washers (M). On certain models, it is necessary to use spacer plate (C) between the cross member assembly and side arms (D).
- All Models: Mount towball coupling (TB) to the towbar faceplate using bolts (G). Use coupling packer (CP) between the towball coupling (TB) and the towbar faceplate. Ensuring all components are square and level, fully tighten all bolts to the specified torque settings.
- All Models: Fit bolt covers (M14-CAP/M12-CAP) to visible fixings (Dependent on variant).
- All Models: Mount electrical socket/harness to the plate provided on the left side of the towbar and complete the installation following the installation guide provided with the electrical harness.

**Towbar: AK4558**  
**For: Motorhomes With Ai-Ko Chassis (From 2006)**  
**Revision: 1**



**General Assembly and Parts Identification.**  
**Refer to Installation Procedure & Correct Illustration Referencing Your Vehicle Model.**

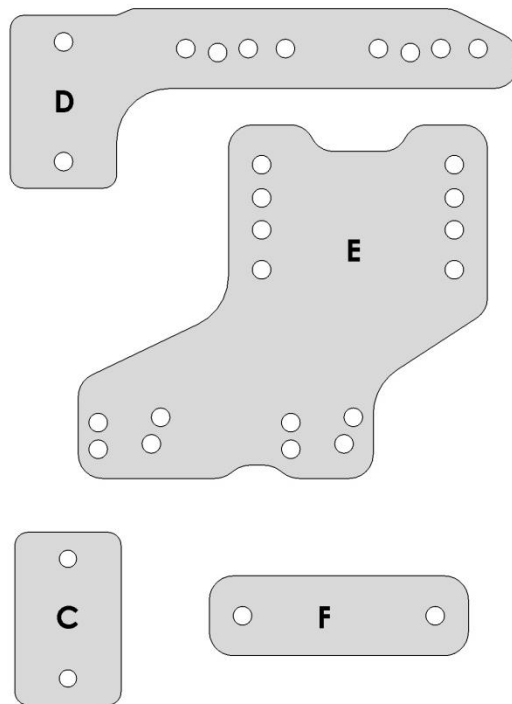
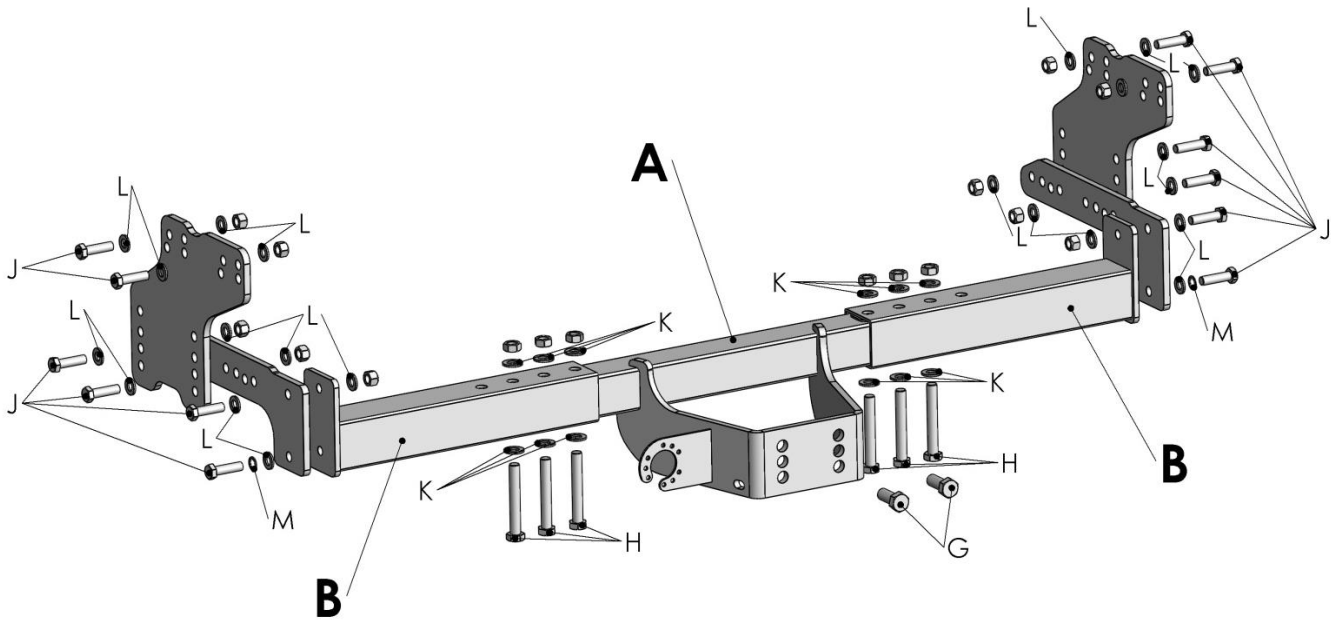

**Towbar: AK4558**  
**For: Motorhomes With Ai-Ko Chassis (From 2006)**  
**Revision: 1**



<b>Illustration:</b>	<b>SWIFT-1</b>
Manufacturer:	Model & Series:
SWIFT	Bessacarr E444 (High-Line)
SWIFT	Hi-Style 644SD (Low-Line)
SWIFT	Sundance 644SD (Low-Line)
Notes: Vehicles With 1215mm Outside to Outside Chassis Width.	
<b>Towbar: All Components Must Be Assembled As Illustrated For The Respective Vehicle Range</b>	
<b>Towball: Towball Must Be Mounted To The Top Hole Set. Use Item CP between towball &amp; towbar.</b>	

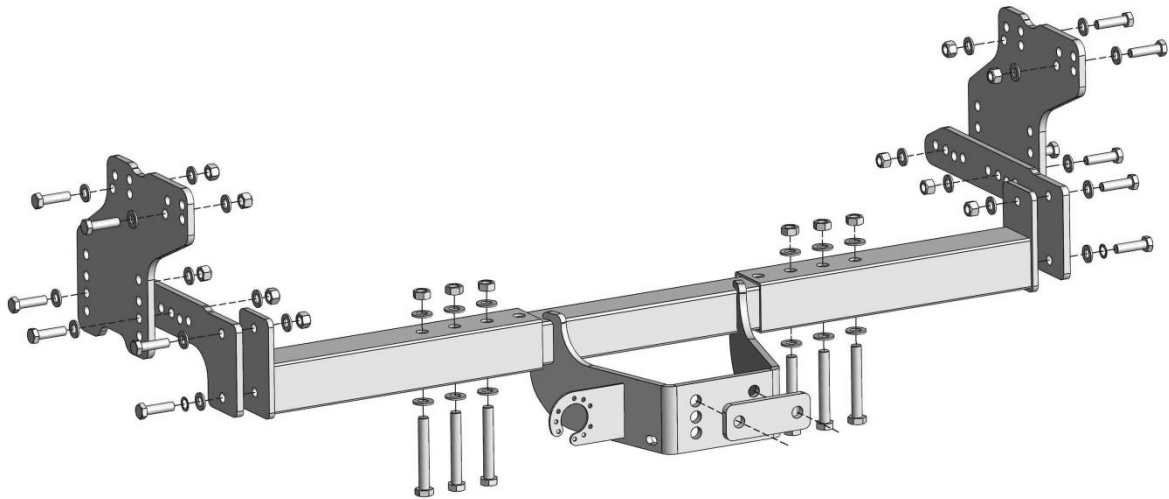

<b>Illustration:</b>	<b>SWIFT-2</b>
Manufacturer:	Model & Series:
SWIFT	Bessacarr E496 (High-Line)
SWIFT	Hi-Style 636L (High-Line)
SWIFT	Sundance 636L (High-Line)
Notes: Vehicles With 1215mm Outside to Outside Chassis Width.	
<b>Towbar: All Components Must Be Assembled As Illustrated For The Respective Vehicle Range</b>	
<b>Towball: Towball Must Be Mounted To The Central Hole Set. Use Item CP between towball &amp; towbar.</b>	

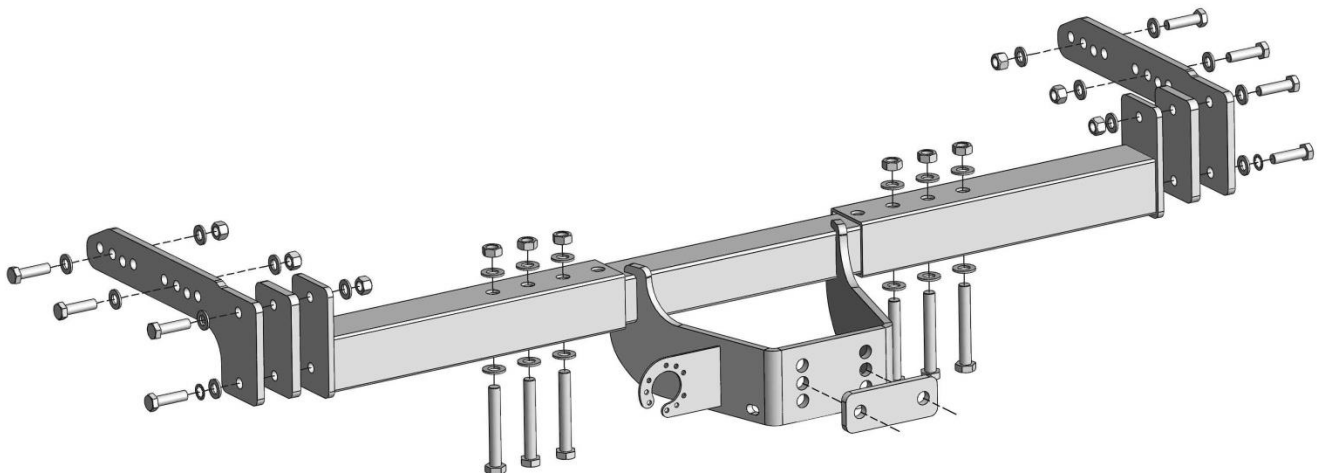

**Towbar: AK4558**  
**For: Motorhomes With Ai-Ko Chassis (From 2006)**  
**Revision: 1**

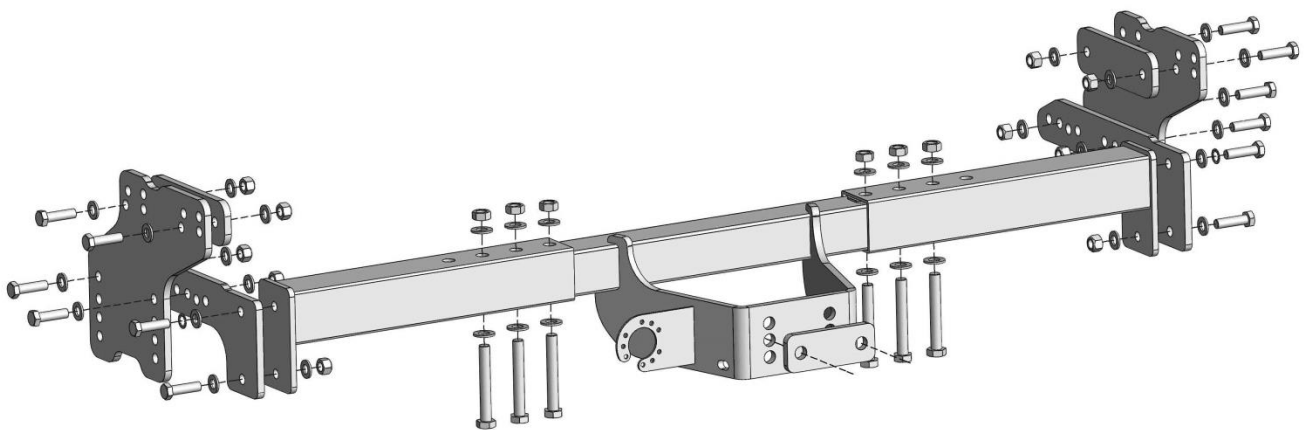

Illustration:	SWIFT-3
Manufacturer:	Model & Series:
SWIFT	Bessacarr E520 (Low-Line)
SWIFT	Bessacarr E540 (Low-Line)
SWIFT	Bessacarr E562 (Low-Line)
SWIFT	Bessacarr E564 (Low-Line)
SWIFT	Bessacarr E572 (Low-Line)
SWIFT	Bessacarr E582 (Low-Line)
SWIFT	Bessacarr E584 (Low-Line)
SWIFT	Bolero 630EW (Low-Line)
SWIFT	Bolero 630PR (Low-Line)
SWIFT	Bolero 682FB (Low-Line)
SWIFT	Bolero 684FB (Low-Line)
SWIFT	Bolero 712SB (Low-Line)
SWIFT	Bolero 722FB (Low-Line)
SWIFT	Bolero 724FB (Low-Line)

Notes: Vehicles With 1288mm Outside to Outside Chassis Width.

**Towbar: All Components Must Be Assembled As Illustrated For The Respective Vehicle Range**

**Towball: Towball Must Be Mounted To The Central Hole Set. Use Item CP between towball & towbar.**



**Towbar: AK4558**  
**For: Motorhomes With Al-Ko Chassis (From 2006)**  
**Revision: 1**

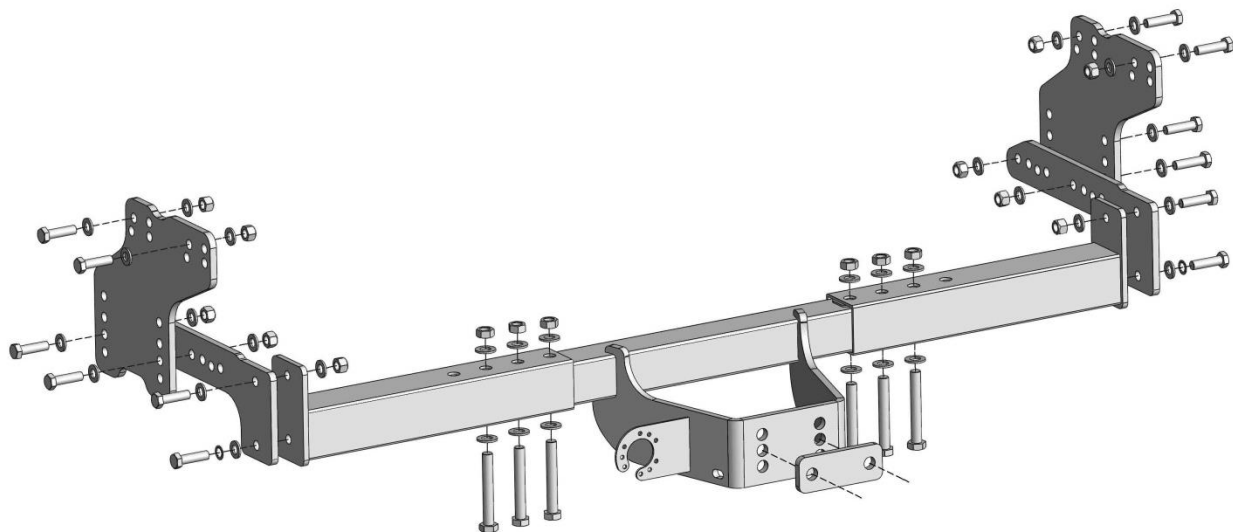

Illustration:	SWIFT-4
Manufacturer:	Model & Series:
SWIFT	Bessacarr E412 (Low-Line)
SWIFT	Bessacarr E434 (High-Line)
SWIFT	Bessacarr E452 (Low-Line)
SWIFT	Bessacarr E454 (Low-Line)
SWIFT	Bessacarr E462 (Low-Line)
SWIFT	Bessacarr E464 (High-Line)
SWIFT	High-Style 532LP (Low-Line)
SWIFT	High-Style 582PR (Low-Line)
SWIFT	High-Style 584PR (High-Line)
SWIFT	High-Style 594RS (High-Line)
SWIFT	High-Style 622FB (Low-Line)
SWIFT	High-Style 622FB (Low-Line)
SWIFT	Sundance 532LP (Low-Line)
SWIFT	Sundance 582PP (Low-Line)
SWIFT	Sundance 584PR (High-Line)
SWIFT	Sundance 594RS (High-Line)
SWIFT	Sundance 622FB (Low-Line)
SWIFT	Sundance 622FB (Low-Line)

Notes: Vehicles With 1307mm Outside to Outside Chassis Width.

**Towbar: All Components Must Be Assembled As Illustrated For The Respective Vehicle Range**

**Towball: Towball Must Be Mounted To The Central Hole Set. Use Item CP between towball & towbar.**





**Towbar: AK4558**  
**For: Motorhomes With Ai-Ko Chassis (From 2006)**  
**Revision: 1**



<b>Illustration:</b>	<b>SWIFT-5</b>
Manufacturer:	Model & Series:
SWIFT	Kon-Tiki 649 (Low-Line & High-Line)
SWIFT	Kon-Tiki 659 (Low-Line & High-Line)
SWIFT	Kon-Tiki 669 (Low-Line & High-Line)
Notes: Vehicles With 1288mm Outside to Outside Chassis Width. Not Suitable For Kon-Tiki 679	
<b>Towbar: All Components Must Be Assembled As Illustrated For The Respective Vehicle Range</b>	
<b>Towball: Towball Must Be Mounted To The Bottom Hole Set. Use item CP between towball &amp; towbar.</b>	

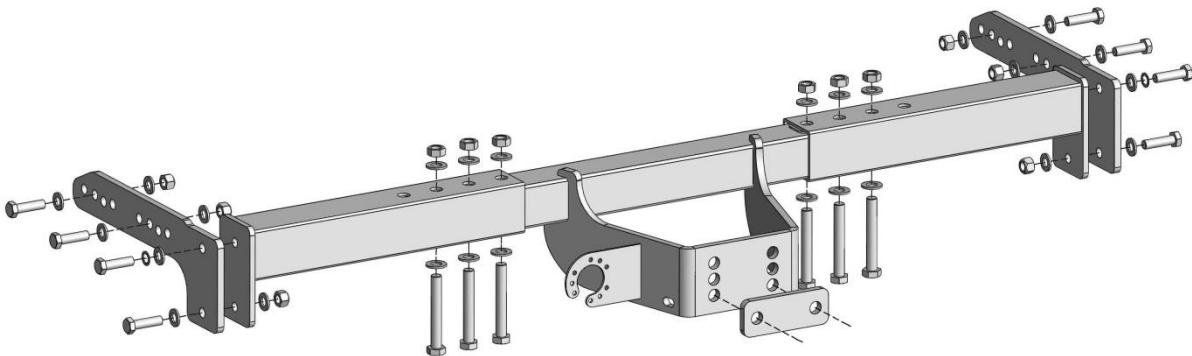

<b>Illustration:</b>	<b>SWIFT-6</b>
Manufacturer:	Model & Series:
SWIFT	Escape 624 (High-Line)
SWIFT	Escape 644 (High-Line)
SWIFT	Escape 664 (Low-Line)
SWIFT	Lifestyle 624 (High-Line)
SWIFT	Lifestyle 644 (High-Line)
SWIFT	Lifestyle 664 (Low-Line)
AUTO-SLEEPER	Broadway SWB on Non-Mercedes Based Vehicles
Notes: Vehicles With 1307mm Outside to Outside Chassis Width.	
<b>Towbar: All Components Must Be Assembled As Illustrated For The Respective Vehicle Range</b>	
<b>Towball: Towball Must Be Mounted To The Central Hole Set. Use item CP between towball &amp; towbar.</b>	

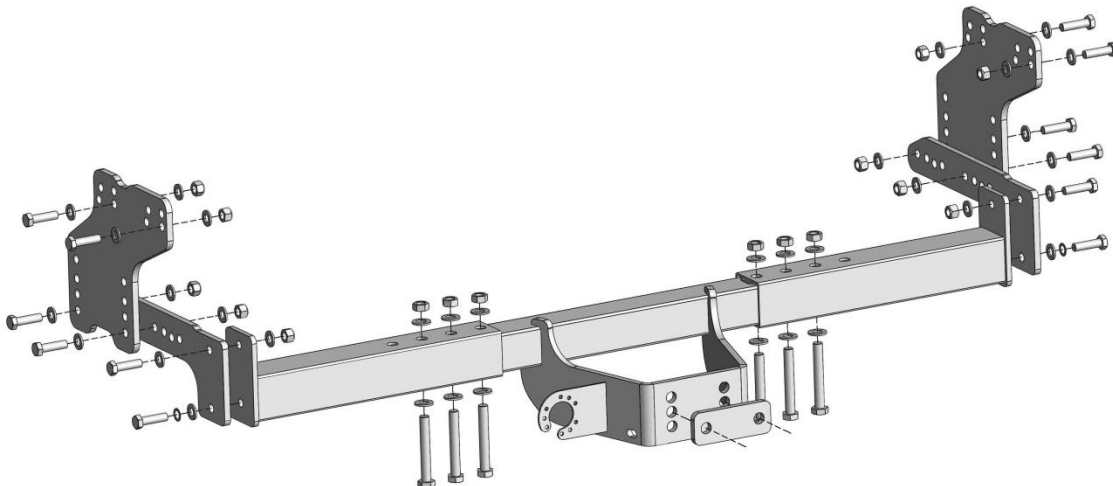



**Towbar: AK4558**  
**For: Motorhomes With Ai-Ko Chassis (From 2006)**  
**Revision: 1**

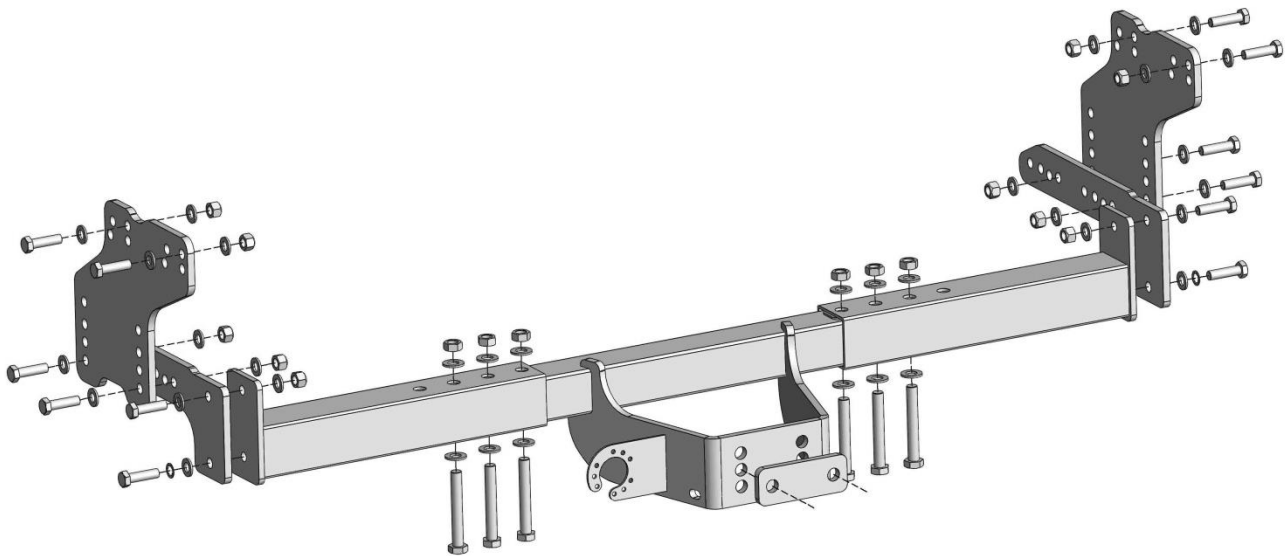

Illustration:	SWIFT-7
Manufacturer:	Model & Series:
SWIFT	Escape 686 (High-Line)
SWIFT	Escape 696 (High-Line)
SWIFT	Lifestyle 686 (High-Line)
SWIFT	Lifestyle 696 (High-Line)
SWIFT	Espirit 412 (Low-Line)
SWIFT	Espirit 462 (Low-Line)
SWIFT	Espirit 464 (High-Line)
SWIFT	Bessacarr 412 (Low-Line)
SWIFT	Bessacarr 442 (Low-Line)
SWIFT	Bessacarr 454 (Low-Line)
SWIFT	Bessacarr 462 (Low-Line)
SWIFT	Bessacarr 464 (High-Line)
AUTO-SLEEPER	Nuevo SWB on Non-Mercedes Based Vehicles

Notes: Vehicles With 1307mm Outside to Outside Chassis Width.

**Towbar: All Components Must Be Assembled As Illustrated For The Respective Vehicle Range**

**Towball: Towball Must Be Mounted To The Central Hole Set. Use item CP between towball & towbar.**



**Towbar: AK4558**  
**For: Motorhomes With Al-Ko Chassis (From 2006)**  
**Revision: 1**



<b>Illustration:</b>	<b>SWIFT-8</b>
Manufacturer:	Model & Series:
SWIFT	Espirit 484 (Low-Line)
SWIFT	Bessacarr 484 (Low-Line)
Notes: Vehicles With 1307mm Outside to Outside Chassis Width.	
<b>Towbar: All Components Must Be Assembled As Illustrated For The Respective Vehicle Range</b>	
<b>Towball: Towball Must Be Mounted To The Central Hole Set. Use item CP between towball &amp; towbar.</b>	

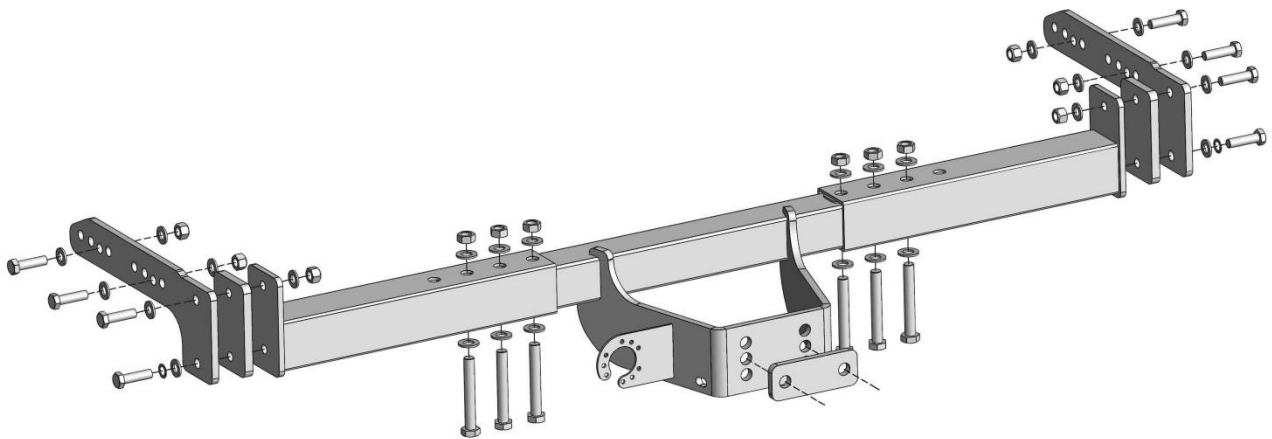

<b>Illustration:</b>	<b>SWIFT-9</b>
Manufacturer:	Model & Series:
SWIFT	Espirit 496 (High-Line)
SWIFT	Bessacarr 496 (High-Line)
Notes: Vehicles With 1215mm Outside to Outside Chassis Width.	
<b>Towbar: All Components Must Be Assembled As Illustrated For The Respective Vehicle Range</b>	
<b>Towball: Towball Must Be Mounted To The Bottom Hole Set. Use item CP between towball &amp; towbar.</b>	

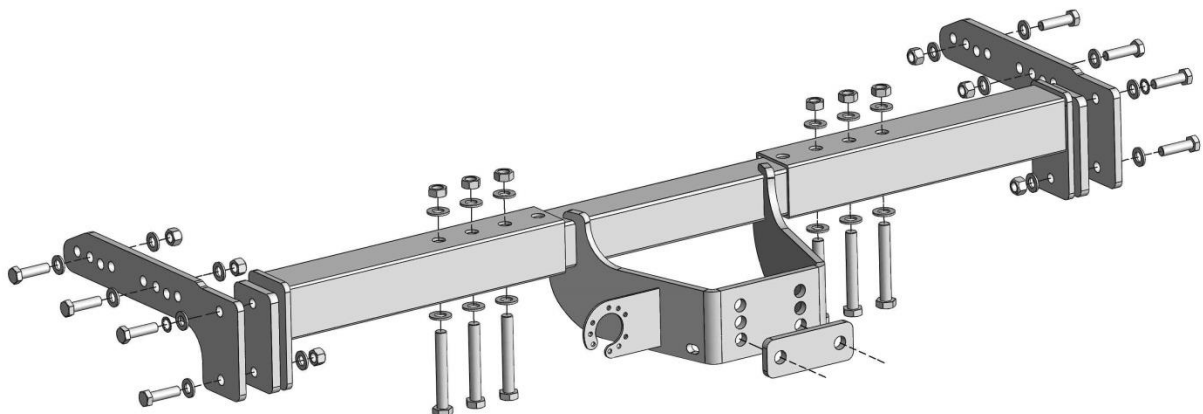

**Towbar: AK4558**  
**For: Motorhomes With Al-Ko Chassis (From 2006)**  
**Revision: 1**



<b>Illustration:</b>	<b>SWIFT-10</b>
Manufacturer:	Model & Series:
SWIFT	Espirit 444 (Low-Line)
SWIFT	Bessacarr 444 (Low-Line)
Notes: Vehicles With 1215mm Outside to Outside Chassis Width.	
<b>Towbar: All Components Must Be Assembled As Illustrated For The Respective Vehicle Range</b>	
<b>Towball: Towball Must Be Mounted To The Central Hole Set. Use item CP between towball &amp; towbar.</b>	

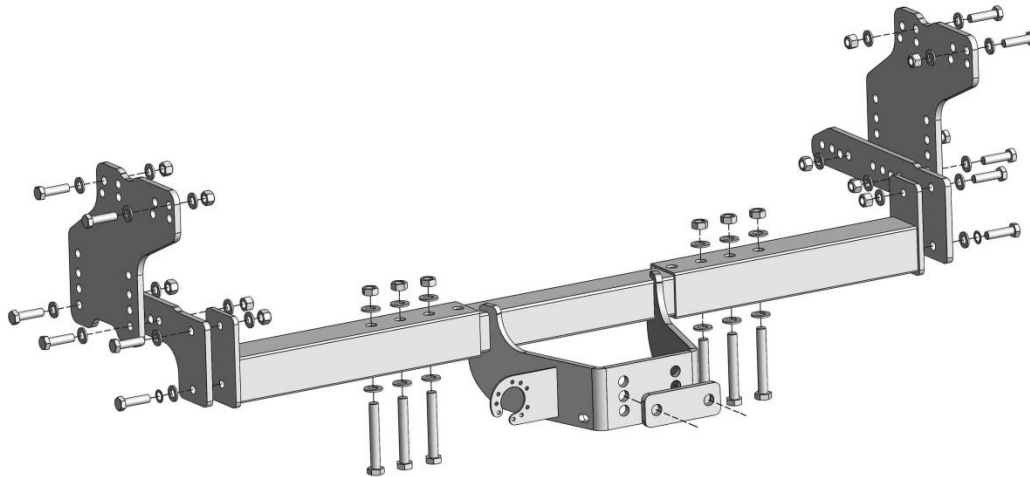

<b>Illustration:</b>	<b>BAILEY-1</b>
Manufacturer:	Model & Series:
BAILEY	Approach Autograph 625
BAILEY	Approach Autograph 740
BAILEY	Approach Autograph 745
BAILEY	Approach Autograph 750
BAILEY	Approach Autograph 765
Notes: Vehicles With 1315mm Outside to Outside Chassis Width.	
<b>Towbar: All Components Must Be Assembled As Illustrated For The Respective Vehicle Range</b>	
<b>Towball: Towball Must Be Mounted To The Lower Hole Set. Use item CP between towball &amp; towbar.</b>	

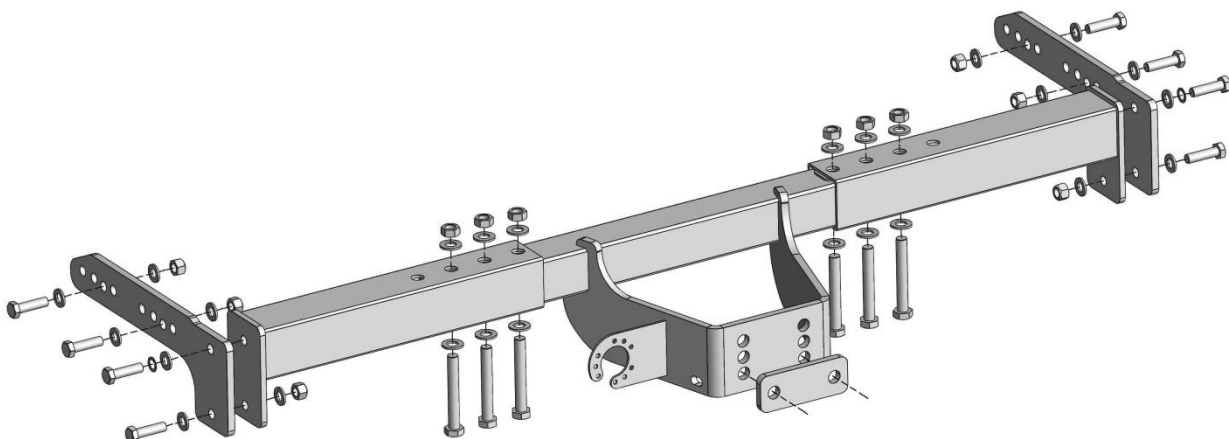

**Towbar: AK4558**  
**For: Motorhomes With Al-Ko Chassis (From 2006)**  
**Revision: 1**



<b>Illustration:</b>	<b>BAILEY-2</b>
Manufacturer:	Model & Series:
BAILEY	Approach SE 620
BAILEY	Approach SE 625
BAILEY	Approach SE 740
BAILEY	Approach SE 745
BAILEY	Approach SE 760
Notes: Vehicles With 1315mm Outside to Outside Chassis Width.	
<b>Towbar: All Components Must Be Assembled As Illustrated For The Respective Vehicle Range</b>	
<b>Towball: Towball Must Be Mounted To The Central Hole Set. Use item CP between towball &amp; towbar.</b>	

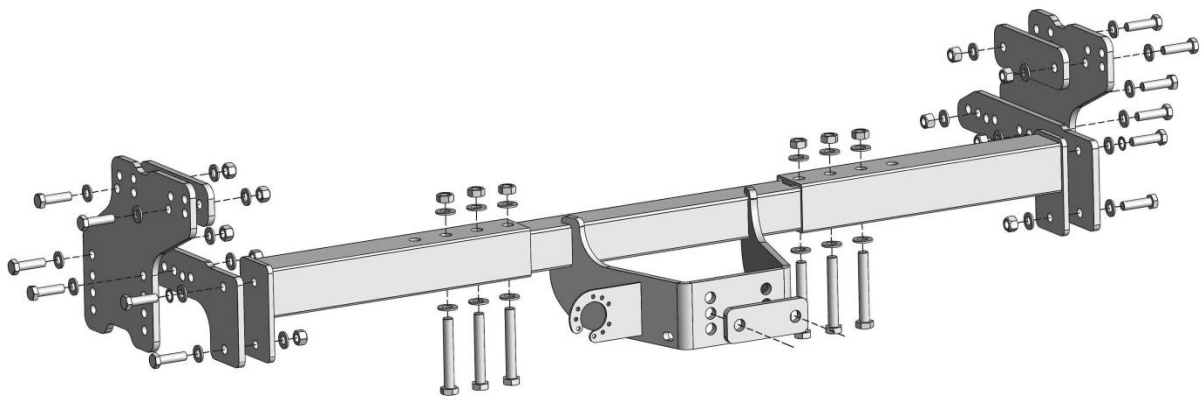

<b>Illustration:</b>	<b>BAILEY-3</b>
Manufacturer:	Model & Series:
BAILEY	Approach Compact 520
BAILEY	Approach Compact 540
Notes: Vehicles With 1315mm Outside to Outside Chassis Width.	
<b>Towbar: All Components Must Be Assembled As Illustrated For The Respective Vehicle Range</b>	
<b>Towball: Towball Must Be Mounted To The Central Hole Set. Use item CP between towball &amp; towbar.</b>	

