

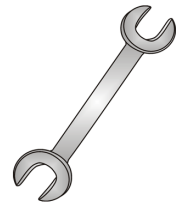

Tow-Trust Towbars

Important: Please read General Notes overleaf before fitting



Issue 5

TVW8 AUDI Q3 2018> / VOLKSWAGEN TIGUAN 2016> / SEAT ATECA 2016> / SEAT TARRACO 2019> / SKODA KODIAQ 2016> / SKODA KAROQ 2018>

Item	Qty	Description	Item	Qty	Description
A	1	TVW8 Crossmember	E	2	M16 x 50 Bolts & Nyloc Nuts
B	2	Handed Side Arms	F	4	M12 x 40 Bolts & S/P Washers
C	2	Spacer Plates	G	4	M12 x 45 Bolts, 2 Nyloc Nuts & 2 S/P Washers
D	1	Extension	H	2	M12 x 40 Bolts & Nyloc Nuts
			J	1	M12 x 120 Bolt (10.9) & Nyloc Nut
			K	4	12 x 40 Flat Washers
			L	8	12 x 25 Flat Washers
			M	1	30mm O/D x 60mm Long Spacer Tube
			N	2	Handed Sensor Brackets
			P	2	M6 x 25 Bolts & Nyloc Nuts

BUMPER REMOVAL:

- All Models:** Remove the rear light clusters.
- Tiguan, Tarraco & Kodiaq:** Remove trim from around wheel arch and remove one fixing from underneath.
- Kodiaq Only:** Remove scuff trim from top edge of bumper to reveal one fixing either side to remove.
- Q3 & Kodiaq:** Remove two wheel arch fixings either side.
- Tarraco Only:** Remove three wheel arch fixings either side.
- Q3 Only:** Remove trim from around wheel arch and remove two fixings from underneath.
- Tiguan, Karoq & Ateca:** Remove four fixings from each wheel arch, pull back wheel arch liner and remove one tip fixing either side.
- All Models:** Remove six fixings from along the lower edge (Tarraco only has four fixings).
- All Models:** Release the bumper from the vehicle body starting at the tips then pull rearward.
- All Models:** Remove the rear impact beam (This is NOT refitted with the Towbar assembly). Always refit the fixings into the rear panel to stop water ingress.

TOWBAR INSTALLATION:

- AdBlue Vehicles:** Lower and support the AdBlue Tank from the O/S to gain access to the Towbar mounting points.
- Locate the Towbar mounting points and clear of any mastic under seal.
- Insert Items **B** into each correct chassis and fix in place using Item **F** with Item **K**.
- Fit Item **A** between each side arm and fix in place using Item **G** with Item **L** (If necessary use Items **C**). **Note:** Use Item **N & P** to remount sensors if fitted.
- Fully tighten all fixings ensuring the Towbar is rigid square and secure.
- AdBlue Vehicles:** Reattach the AdBlue Tank to the vehicle.
- Refit the rear bumper. (**Kodiaq:** Cut bumper as per the sketch below / **Karoq:** Cut pre marked area)
- Using Item **H** with Item **L** and Item **J** with Item **L** fix Item **D** to Item **A** ensuring Item **M** is fitted between the lower point.
- Using Item **E** fix your desired ball bracket and wiring plate (Not supplied in this kit) to Item **D**.
- Fully tighten the remaining fixings.

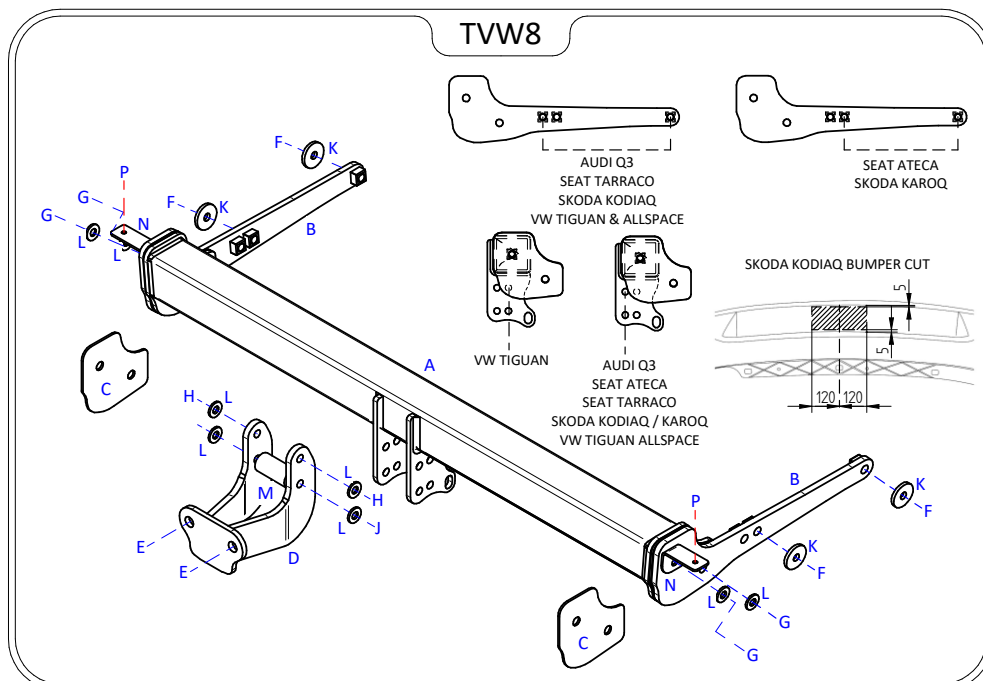

Note:

- Recommended Torque Setting for M12 Grade 10.9 -130 Nm. (For other Torque Settings see notes overleaf.)
- Nose load limits and vehicle manufacturers trailer / caravan weight limits must be observed.